

Nominal voltage	230 V - 50Hz		
Power supply tolerances	205 - 255 V		
Thermal time	4 minutes for all motors		
Number of wires of the cable	3		
Wire section	0,75 mm ²		
Type of limit switch unit	Electronic		
Capacity of the LSU	200 *		
Repeatability	<± 3° *		
System of protection	IP 44		
Interface drawing	Screw implantation for LT50 mounting 206810-Wheel interface LT50 206821-Crown interface LT50 206822-Interface drawing star head LT50 and LT50PA/PS 206823-		
Coding	Rolling code 16 million of possibilities		
Capacity of memory	12 different codes plus 3 wireless sensors		
Range	20 m with 2 reinforced concrete walls to be passed through		
Service stress			
Electromagnetic compatibility	CEI 1000-4-2	8 kV minimum	
	CEI 1000-4-3	level III	
	CEI 1000-4-4	level III	
Standard	IETS 300-220 *		
Basic crown for tube Ø	50 x 1,5 mm		
Temperature working range	Normal use : -10°C to +40°C Exceptionnal use (20% of the life time not simultaneous) : -20°C to + 70°C		
Noise level	According to SOMFY measures (for information only).Worse value : in load up direction during 10 seconds.		

Designation	Nm		Reference	mm				W	A	°C	kg	dBA	mm		µF
	Nominal torque	Nominal speed		L1 max.	L2 (±3 mm)	L3 max.	tube						Stator	Capacitor	
OXIMO RTS 6/17 LTH	6	17	5005465C	675	660	683	610	240	1.1	150	sliding	2.55	55	100	2
OXIMO RTS 6/17	6	17	5005459C	605	590	613	540	90	0.45	140	sliding	1.72	47	35	2.5
OXIMO RTS 10/17	10	17	5005460C	655	640	663	590	120	0.5	140	sliding	1.85	47	40	3.5
OXIMO RTS 15/17	15	17	5005461C	655	640	663	590	140	0.65	150	sliding	1.95	50	55	4.5
OXIMO RTS 20/17	20	17	5005462C	655	640	663	590	160	0.75	150	sliding	2.15	53	70	5.5
OXIMO RTS 30/17	30	17	5005463C	675	660	683	610	240	1.1	150	sliding	2.55	55	100	7
OXIMO RTS 40/17	40	17	5005464C	745	730	753	680	270	1.2	140	coil brake	2.8	57	100	7

WIRING	Neutral	Blue
	Live	Brown
	Earth	Green / Yellow

Reversal of the direction (Oct'08): By Push the UP and DOWN button until the motor moves twice UP and DOWN briefly and by pushing the stop button of the transmitter during 2"

Get control : Push the UP and DOWN button of the control in order to get control of the motor after the first power on during the factory mode

Reset of the memory : 1- double cut-off with making alive from 5" to 10".

2- push briefly the programming button of a new transmitter until the motor moves twice UP and DOWN briefly.

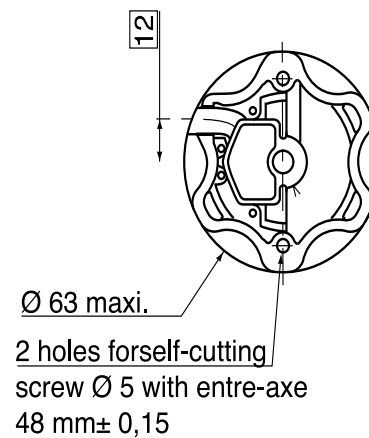
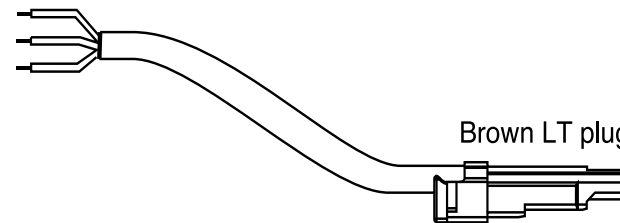
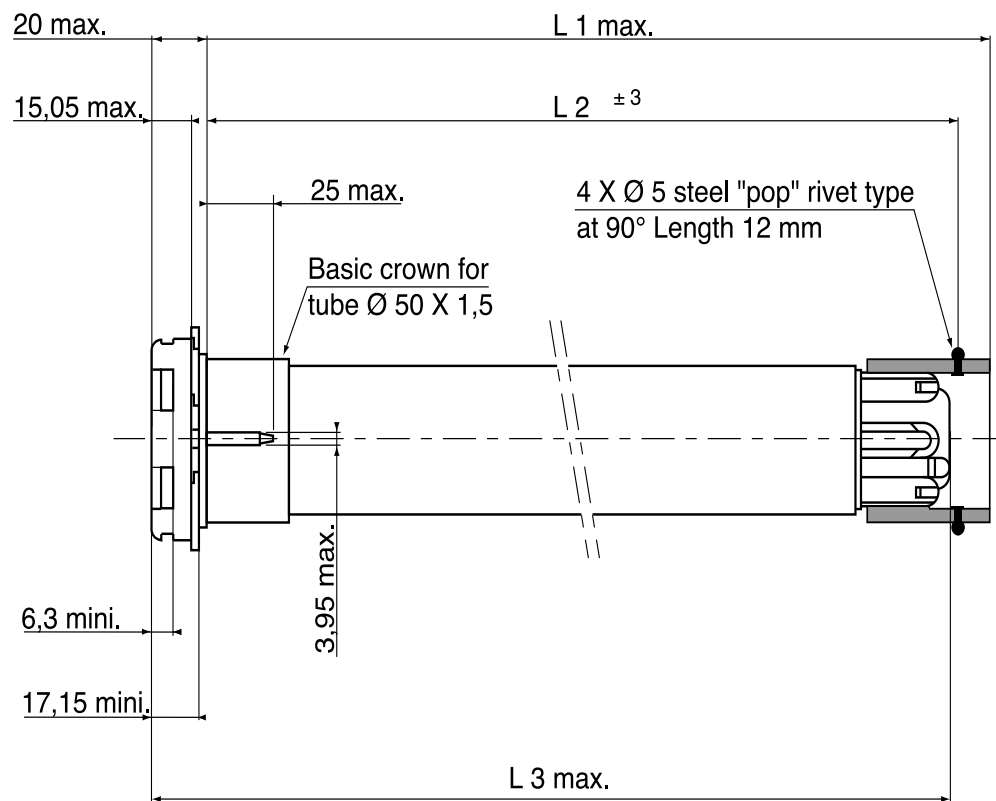

Visa :	DT	Quality	GMD
--------	----	---------	-----