

Guía de instalación

Installation guide

Notice d'installation

Guia de instalação

SGH RTS
SOMFY

Réf. 5 003 770 C

1	E Antes de realizar la instalación, leer cuidadosamente las instrucciones de seguridad adjuntas.	GB Before installation please read carefully the safety instructions on the sheet included.	F Avant la mise en oeuvre veuillez lire les instructions de sécurité ci-joint.	P Antes da instalação, por favor leia com cuidado as instruções incluídas na folha.
2	E Instalación del operador	GB Motor installation	F Installation du moteur	P Instalação do operador
3	E Ajuste de los finales de carrera y basculación	GB Limit adjustment and tilting	F Réglage fin de course et basculation	P Ajuste dos fins de curso e basculação
4	E Modo de instalación	GB Installation mode	F Mode installation	P Modo de instalação
5	E Modo de uso	GB Use mode	F Mode utilisation	P Modo de uso
6	E Guía de diagnóstico	GB Trouble shooting	F Dépannage	P Guia de diagnóstico

- E** Antes de realizar la instalación, leer cuidadosamente las instrucciones de seguridad adjuntas.
- GB** Before installation, please read carefully the safety instructions on the sheet included.
- F** Avant la mise en œuvre veuillez lire les instructions de sécurité ci-joint.
- P** Antes da instalação, por favor leia com cuidado as instruções incluídas na folha.

- E** • Si la instalación está compuesta de varios SGH RTS, sólo un SGH RTS debe ser alimentado durante la programación. Esto evitará interferencias en la primera programación de cada operador SGH RTS.
- GB** • If the installation is made up of several SGH RTS, only one SGH RTS motor must be powered during programming. This will avoid interference with the first programming of each SGH RTS motor.
- F** • Si l'installation comporte plusieurs SGH RTS, un seul moteur doit être alimenté pendant la phase de programmation. Ceci évitera les interférences avec les autres moteurs lors de la première programmation.
- P** • Se a instalação é composta por vários SGH RTS, só um SGH RTS deve ser alimentado durante a programação. Isto evitará interferências na primeira programação de cada operador SGH RTS.

- E** La responsabilidad y la garantía de Somfy quedan anuladas en caso de incumplimiento de estas instrucciones. Somfy no se hace responsable de los cambios en la normativa introducidos después de la publicación de esta guía
- GB** The failure to respect these instructions annuls Somfy's responsibility and guarantee. Somfy cannot be held responsible for any changes in norms and standards introduced after the publication of this guide.
- F** Le non-respect de ces instructions annule la responsabilité de SOMFY et sa garantie. SOMFY ne peut être tenue responsable des changements de normes et standards intervenus après la publication de cette notice.
- P** O não respeito às instruções neste manual exclui toda a responsabilidade e garantia por parte da Somfy. Somfy não poderá ser responsabilizada por eventuais por alterações normativas, posteriores à edição deste manual.



E Símbolos utilizados en esta guía
F Symboles utilisés dans votre notice

GB Symbols used in this booklet
P Símbolos utilizados no seu livrete

Estado del producto portador • End-product status • Etat du produit porteur • Situação do produto portador •



Breve movimiento (arriba/abajo) • **Short up & down movement**
• Bref mouvement (bonne réception) • **Breve movimento (cima/abaixo)**



Posición baja • **Low position** • Position basse • **Posição baixa**



Posición alta • **High position** • Position Haute • **Posição alta**



Programación correcta • **Executed setting** • Réglage terminé
• **Programação correcta**



Programación borrada • **Deleted setting** • Réglage supprime •
Programação de Apagar



Ajuste manual • **Manual adjustment** • Ajustement manuel • **Ajuste manual**



- E** Emissores compatibles
- F** Pour télécommander votre moteur

- GB** Compatible RTS controls
- P** Para controlar com um emissor o seu operador

Telis 1 RTS



Telis 4 RTS



Centralis SGH RTS



Soliris sensor RTS



Capacidad de memoria
 Memory capacity
 Capacité mémoire
 Capacidade de memória

12



Radio Technology Samfy™

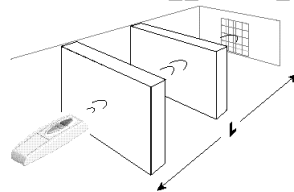

	L)))
Telis 1 RTS	20m / 78,7in	433,42 Mhz
Tellis 4 RTS		
Centralis SGH RTS		
Soliris sensor RTS		

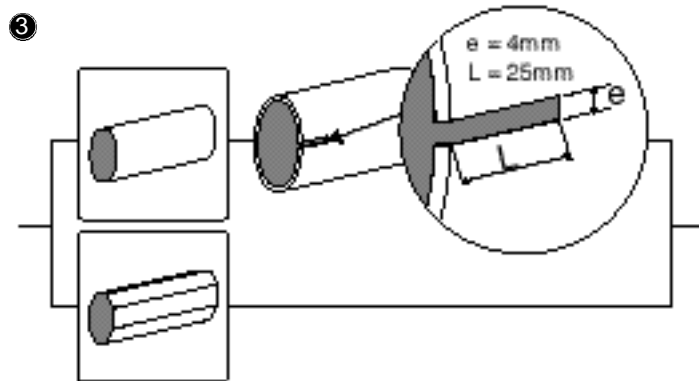
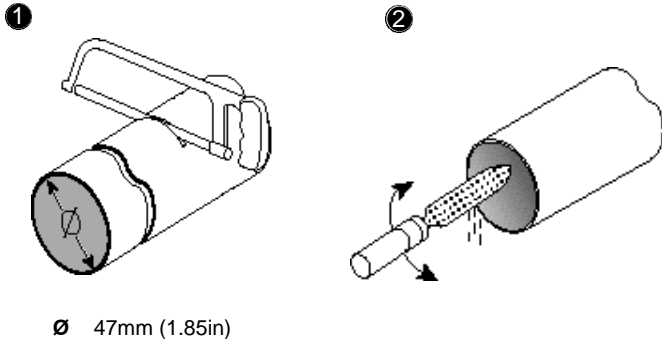
2**E** INSTALACIÓN DEL OPERADOR
Preparación del tubo**GB** MOTOR INSTALLATION
Tube preparation**F** INSTALLATION DU MOTEUR
Préparation du tube**P** INSTALAÇÃO DO OPERADOR
Preparação do tubo

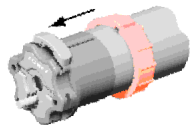
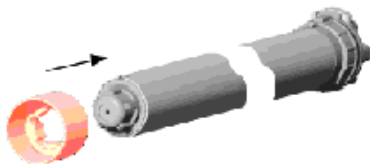
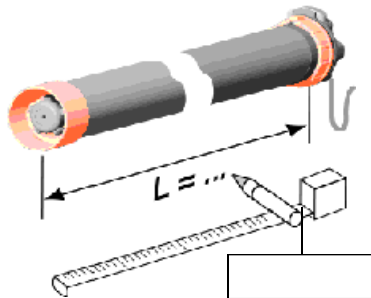
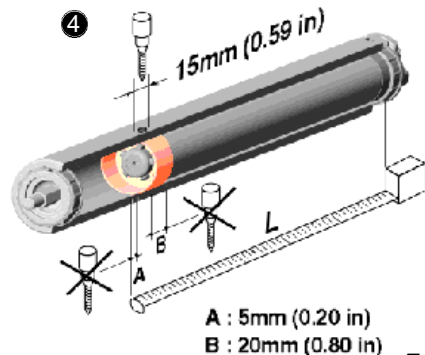
2**E** INSTALACIÓN DEL OPERADOR
Montaje del operador**GB** MOTOR INSTALLATION
Motor mounting**F** INSTALLATION DU MOTEUR
Assemblage du moteur**P** INSTALAÇÃO DO OPERADOR
Montagem do operador**1****2****3****4****5**

2**E** **INSTALACIÓN DEL OPERADOR**
Instalar el tubo en los soportes**GB** **MOTOR INSTALLATION**
Install the tube on the brackets**F** **INSTALLATION DU MOTEUR**
Installer le tube sur ses supports**P** **INSTALAÇÃO DO OPERADOR**
Instalar o tubo nos suportes**1****2****1****2****3**

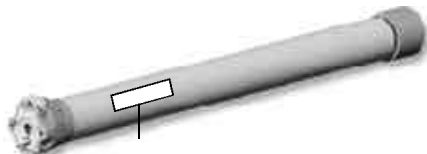
2**E** **INSTALACIÓN DEL OPERADOR**
Alimentación y cableado**GB** **MOTOR INSTALLATION**
Power supply and wiring**F** **INSTALLATION DU MOTEUR**
Alimentation et câblage**P** **INSTALAÇÃO DO OPERADOR**
Alimentação e cablagem**1** **Comprobar -Check - Vérifier - Verificar -**

230 v / 50 Hz		
1	2	3
Azul, Blue, Bleu, Azul,	Marrón, Brown, Marron, Castanho,	Verde-amarillo, Green-yellow, Vert-jaune, Verde - amarel

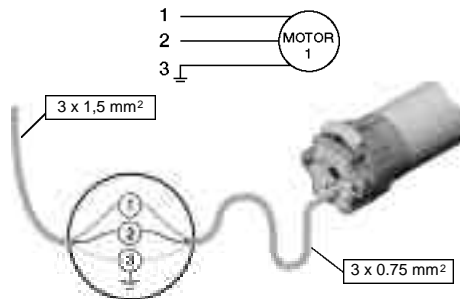
2 **Alimentación -Supply - Alimenter - Alimentação**

- 1 Neutro, **neutral**, neutre, **neutro**,
 2 Fase, **live**, phas, **live**,
 3 Tierra, **earth**, terre, **terra**

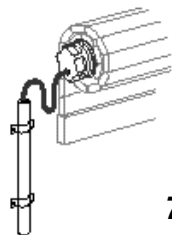
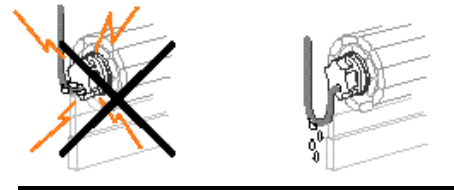

3

E AJUSTE DE LOS FINALES DE CARRERA Y BASCULACIÓN
Programación del sentido de rotación

GB LIMIT ADJUSTMENT AND TILTING
Programming direction of rotation

F RÉGLAGE FIN DE COURSE ET BASCULATION
Programmation du sens de rotation

P AJUSTE DOS FINS DE CURSO E BASCULAÇÃO
Programação do sentido de rotação



2

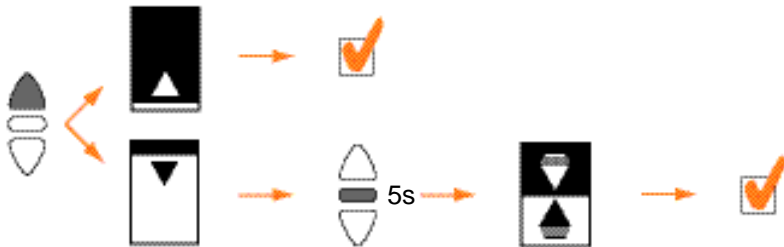

1 Identificación, *identification*,
identifier, *identificação*,

2 Comprobación sentido de rotación, *rotation direction checking*,
vérification du sens de rotation, *comprovação do sentido de rotação*,

3

E AJUSTE DE LOS FINALES DE CARRERA Y BASCULACIÓN
Regulación del final de carrera

GB LIMIT ADJUSTMENT AND TILTING
Limit adjustment

F RÉGLAGE FIN DE COURSE ET BASCULATION
Réglage fin de course

P AJUSTE DOS FINIS DE CURSO E BASCULAÇÃO
Regulação do fim de curso

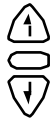
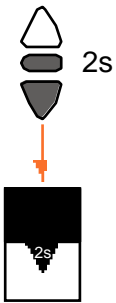
3

3. Posición baja, **low position**, position basse, **posição baixa**

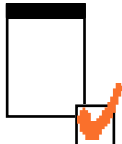
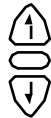
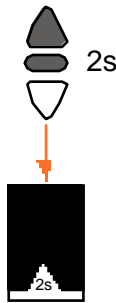
4

4. Posición alta, **high position**, position haute, **posição alta**

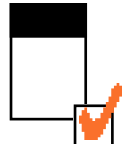
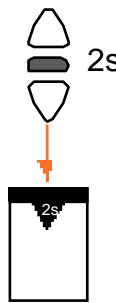
5

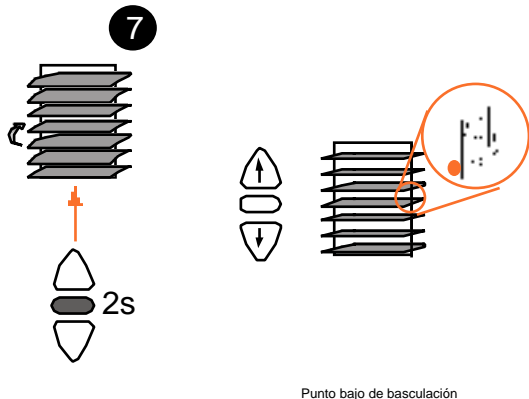
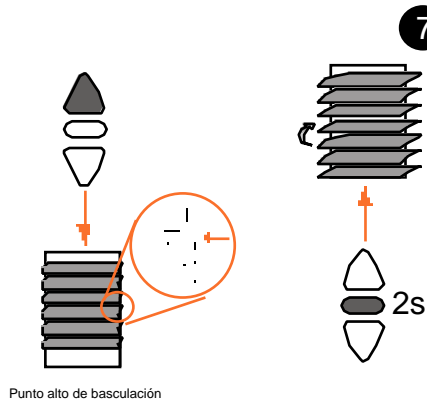

3

E AJUSTE DE LOS FINALES
DE CARRERA Y BASCULACIÓN
Regulación de basculación 2

GB LIMIT ADJUSTMENT
AND TILTING
Tilting adjustment 2

F RÉGLAGE FIN DE COURSE
ET BASCULATION
Réglage de basculation 2

P AJUSTE DOS FINIS DE CURSO
E BASCULAÇÃO
Regulação do basculação 2

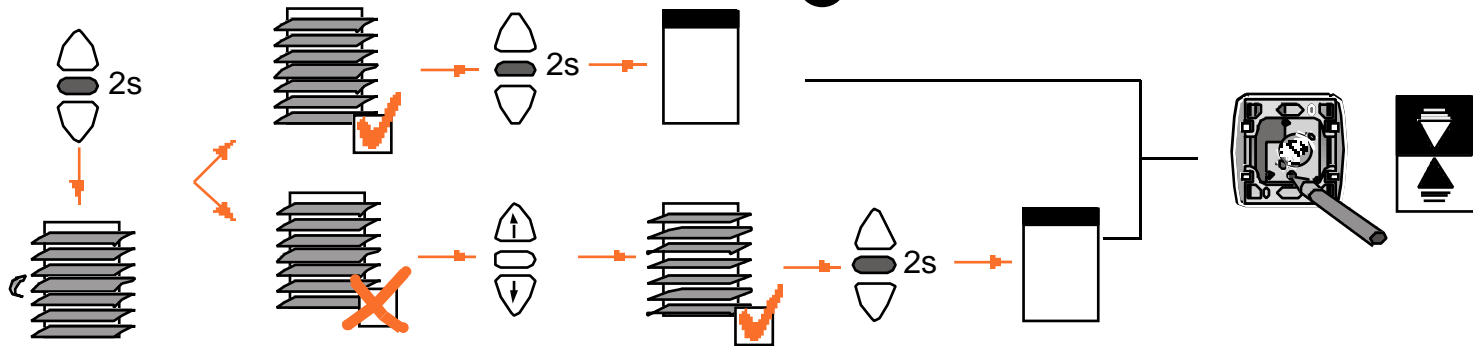

4

E MODO DE INSTALACIÓN
Añadir o borrar un emisor
de la memoria del operador

GB INSTALLATION MODE
Add or delete a control in
the memory of motor

F MODE INSTALLATION
Ajout ou suppression d'un
émetteur dans la mémoire moteur

P MODO DE INSTALAÇÃO
Adicionar ou apagar um emissor
da memória do operador

Con la ayuda de un emisor ya grabado • *With help of a recorded control* • A l'aide d'un émetteur mémorisée • *Com a ajuda de um emissor já gravado*

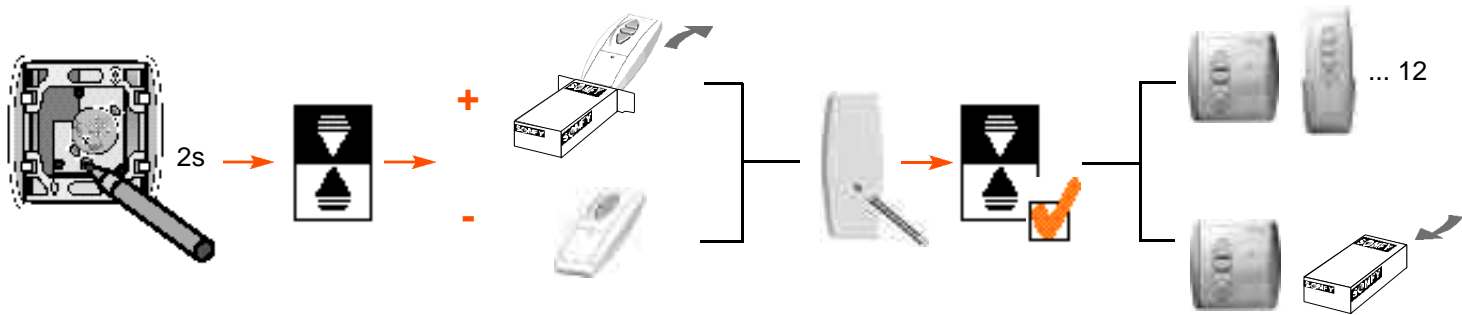

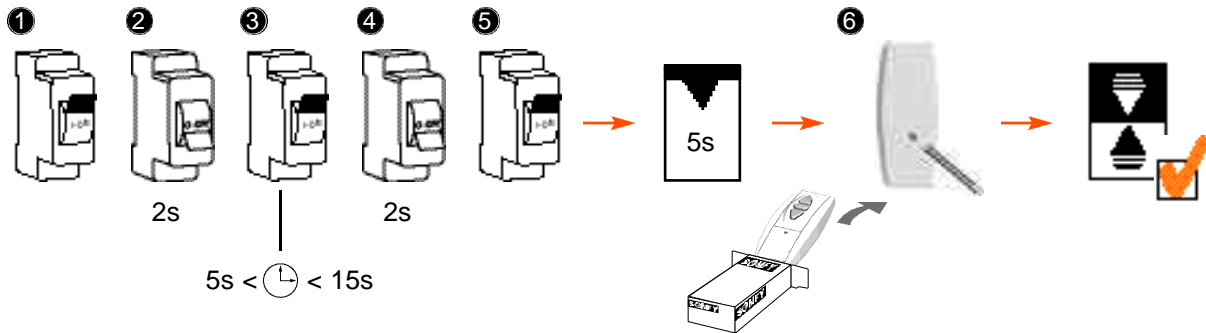
4**E** MODO DE INSTALACIÓN
Reemplazar un emisor perdido**GB** INSTALLATION MODE
Replacement of a lost
remote control**F** MODE INSTALLATION
Remplacement
d'un émetteur perdu**P** MODO DE INSTALAÇÃO
Substituição de um
emissor perdido

4

E MODO DE INSTALACIÓN
Reset (puesta a cero del
operador)

GB INSTALLATION MODE
Reset

F MODE INSTALLATION
Reset

P MODO DE INSTALAÇÃO
Reset

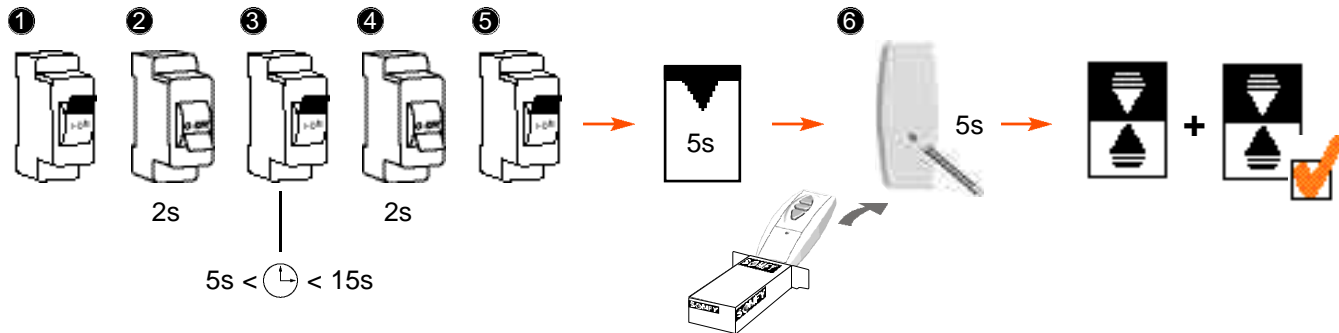

5

E MODO DE USO
Uso del producto

GB USE MODE
Use of the product

F MODE UTILISATION
Utilisation

P MODO DE USO
Utilização

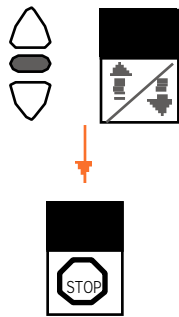
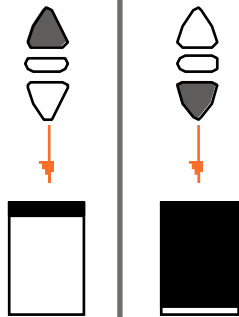

Entrar a basculación

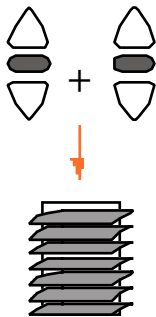

Funcionamiento en basculación

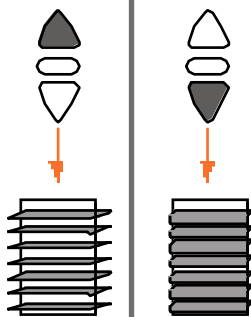

Salida de basculación

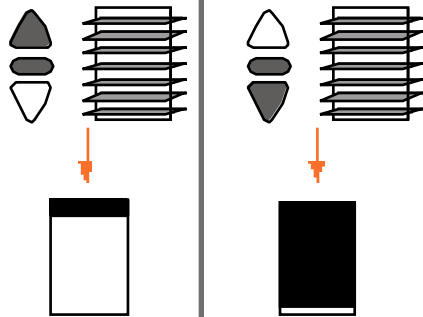

5

E MODO DE USO
Modificar la posición de
orientación predeterminada

GB USE MODE
Modify the predetermined
orientation position

F MODE UTILISATION
Modifier la position
de orientation prédéterminé

P MODO DE USO
Modificar a posição
de orientação

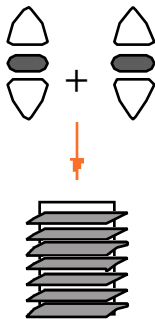
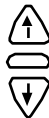
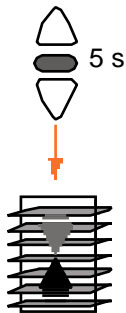
1**2****3**

❑ El operador no funciona cuando se le envía una orden:

Comprobar:

- el cableado del operador,
- si está accionada la protección térmica (esperar que el operador recupere su temperatura de funcionamiento),
- el cable utilizado (3 hilos),
- la batería del emisor,
- la compatibilidad del emisor,
- que el proceso de memorización del emisor ha sido correctamente realizado, (ver capítulo 3),
- la ausencia de radio interferencias,

❑ El sistema se para antes de alcanzar los finales de carrera:

Comprobar:

- la correcta colocación de la corona y que ésta gire a la par con el tubo,
- la correcta fijación de la rueda motriz con el tubo de enrollamiento (ver capítulo 2),
- que los finales de carrera han sido correctamente programados (ver capítulo 3).

❑ The motor doesn't work :

Verify :

- the wiring of motor,
- the heat generated (wait for the cooling of motor),
- the suitability of the cable used (3wires),
- the battery of the remote control,
- the compatibility of remote control,
- the control is properly programmed into the memory of the motor (see § 3),
- there is no interference from other radio equipment.

❑ The equipment stops too soon :

Verify :

- the operation of end-limits during the rotation of motor,
- the crown is properly fitted to the tube (see § 2),
- the end-limits of motor are properly adjusted (see § 3).

Le moteur ne fonctionne pas :

Vérifier :

- le câblage du moteur,
- le contact thermique (attendre le refroidissement du moteur),
- la conformité du câble utilisé (3 conducteurs),
- la batterie de la télécommande,
- la compatibilité des télécommandes,
- la bonne mémorisation de la télécommande par le moteur (voir paragraphe 3)
- l'absence d'interférences radio.

 L'appareillage s'arrête trop tôt :

Vérifier :

- le fonctionnement des fins de course pendant la rotation du moteur,
- que la couronne d'entraînement est bien solidarisée au tube (voir § 2)
- que les fins de course du moteur soient bien réglées (voir § 3).

 Guia de diagnóstico: **Operador não funciona quando se envia uma ordem:**

Verificar:

- o cabo de alimentação do operador,
- se está accionada a protecção térmica (esperar que o operador recupere a sua temperatura de funcionamento),
- a conformidade do cabo utilizado (3 fios),
- a bateria do emissor,
- a compatibilidade do emissor,
- que o processo de memorização do emissor tenha sido correctamente realizado (capítulo 3),
- interferências radio.

 Sistema pára antes de alcançar os fins de curso:

Verificar:

- a correcta colocação da coroa e que esta gire a par do motor,
- a correcta fixação da roda motriz com o tubo de enrolamento (capítulo 2),
- que os fins de curso tenham sido correctamente programados (capítulo 3).

E  Nosotros, Sociedad SOMFY, declaramos que este producto está en conformidad con los requisitos esenciales y otras provisiones relevantes del directivo 1999/5/EC . Una declaración de la conformidad queda a disposición en el Internet a las señas www.somfy.com Rubrique CE

F  Nous SOMFY, déclarons que ce produit est conforme aux exigences essentielles et autres dispositions pertinentes de la directive 1999/5/EC. Une déclaration de conformité est mise à disposition à l'adresse Internet www.somfy.com rubrique CE.

GB  Hereby, SOMFY, declares that this equipment is in compliance with the essential requirements and other relevant provisions of Directive 1999/5/EC.
A Declaration of Conformity is available at the web address www.somfy.comHeading CE

P  A SOMFY declara que este equipamento cumpre os requisitos essenciais e outras normativas relevantes da Directiva 1999/5/EC. Uma Declaração de Conformidade encontra-se disponível na Internet em www.somfy.comHeading CE.



www.somfy.com

Australia : SOMFY PTY LTD
www.somfy.com

Austria : SOMFY GesmbH
www.somfy.at

Belgium : NV SOMFY SA
www.somfy.be

Brasil : SOMFY BRASILSTDA
www.somfy.com

Canada : SOMFY ULC
www.somfy.com

Cyprus : SOMFY MIDDLE EAST
www.somfy.com

Czech Republic : SOMFY Spol s.r.o.
www.somfy.com

Denmark : SOMFY AB DENMARK
www.somfy.se

Finland : SOMFY FINLAND AB
www.somfy.se

France : SOMFY FRANCE
www.somfy.fr

Germany : SOMFY GmbH
www.somfy.de

Greece : SOMFY HELLAS
www.somfy.com

Hong Kong : SOMFY Co. Ltd
www.somfy.com

Hungary : SOMFY Kft
www.somfy.com

India : SOMFY INDIAPVT Ltd
www.somfy.com

Italy : SOMFY ITALIA S.R.L.
www.somfy.com

Japan : SOMFY KK
www.somfy.co.jp

Lebanon : cf. Cyprus - SOMFY MIDDLE EAST
www.somfy.com

Mexico : SOMFY MEXICO SA de CV
www.somfy.com.mx

Morocco : SOMFY MAROC
www.somfy.com

Netherlands : SOMFY BV
www.somfy.nl

Norway : SOMFY NORWAY
www.somfy.se

Poland : SOMFY SP Z.O.O
www.somfy.pl

Portugal : cf. Spain - SOMFY ESPAÑA SA
www.somfy.com

Russia : cf. Germany - SOMFY GmbH
www.somfy.de

Singapore : SOMFY PTE LTD
www.somfy.com.sg

Slovaquia : cf. Czech Republic - SOMFY Spol s.r.o.
www.somfy.com

South Korea : SOMFY JOO
www.somfy.co.kr

Spain : SOMFY ESPAÑASA
www.somfy.com

Sweden : SOMFY AB
www.somfy.se

Switzerland : SOMFY A.G.
www.somfy.ch

Taiwan : SOMFY TAIWAN
www.somfy.com

United Kingdom : SOMFY LTD
www.somfy.co.uk

United States : SOMFY SYSTEMS Inc
www.somfysystems.com