

Lire attentivement cette notice avant toute utilisation.
 Read carefully these instructions before any use.
 Deze handleiding aandachtig doorlezen alvorens het systeem te gebruiken.
 Bitte gründlich vor der Anwendung lesen.
 Lea atentamente estas instrucciones de montaje antes de cualquier utilización.
 Ler attentamente as instruções antes de proceder a qualquer utilização.
 Leggere attentamente queste istruzioni prima dell'uso.

5008051G

FR - GB - DE - NL - ES - PT - IT

SOMFY SAS, 50 avenue du Nouveau Monde 74300 CLUSES - FRANCE - & (33) 4 50 96 70 00 - capital 20.000.000 € - RCS Bonneville 303.970.230

Moteur standard - Standard motor - Standardmotor - Standard motor - Motor estandar - Motor standard - Motore standard

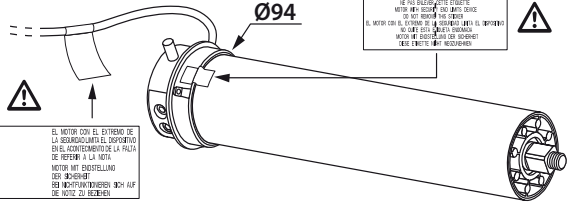

**Moteur avec manœuvre de dépannage - Motor with manual override - Motor mit NHK - Motor met noodhandbedienning
 Motor con mando manuale de seguridad - Motor com comando de recurso - Motore con manovra di soccorso**

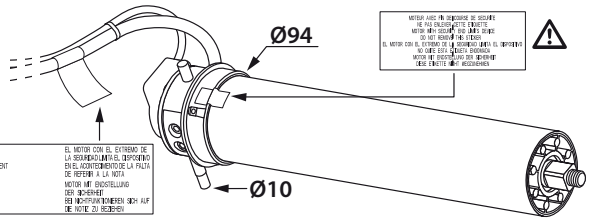
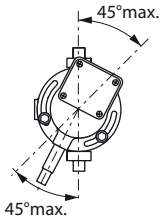

**1 MONTAGE DES ADAPTATIONS- MOUNTING THE ADAPTORS - MONTAGE VAN DE ADAPTIES - ADAPTERMONTAGE
 MONTAJE DE LAS ADAPTACIONES- MONTAGEM DOS ADAPTADORES- MONTAGGIO DEGLI ADATTATORI**

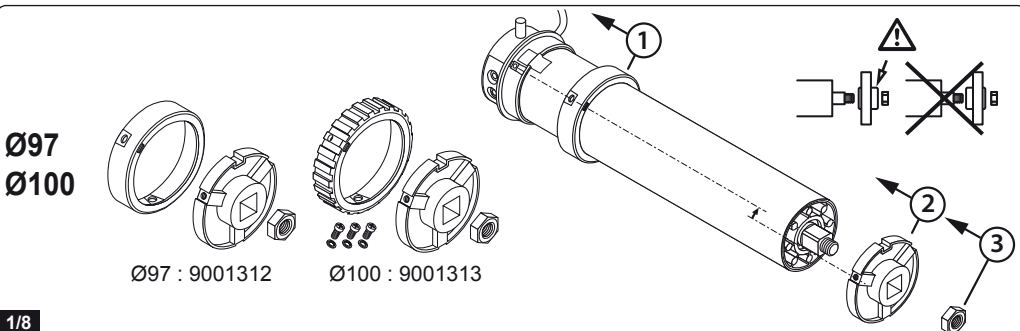
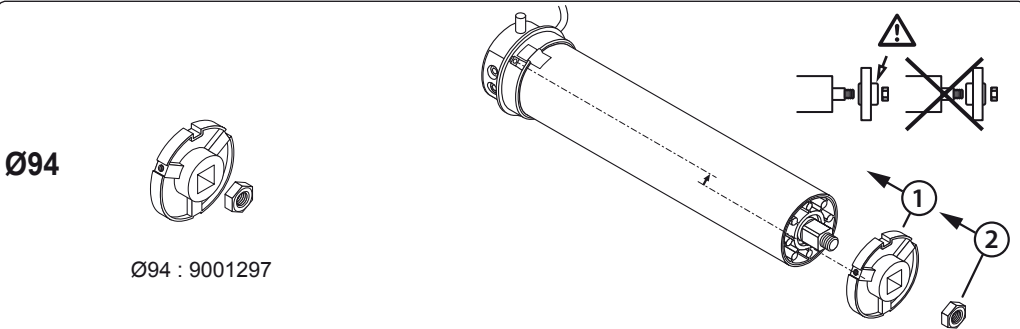

Ø119
Ø124
Ø127

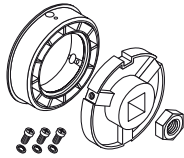

Ø119 : 9013826

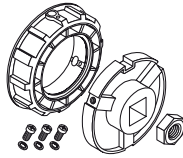

Ø124 : 9013824

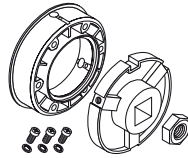

Ø128 : 9013822

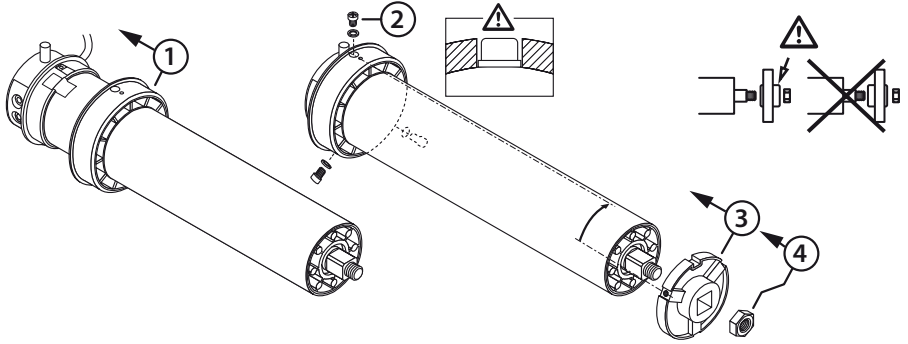

Ø131
Ø133

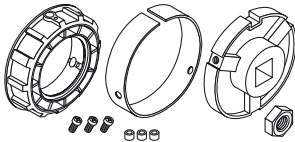

Ø131 : 9013437
Ø133 : 9013438

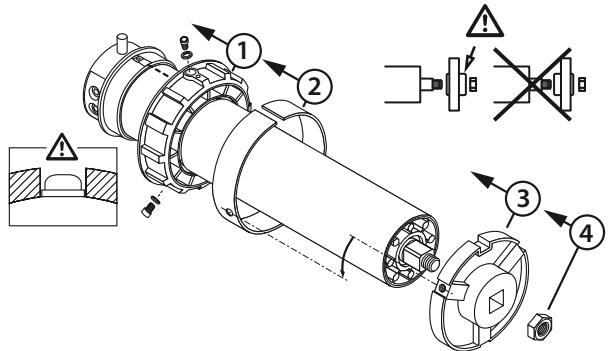

Ø149
Ø152
Ø158
Ø160
Ø168

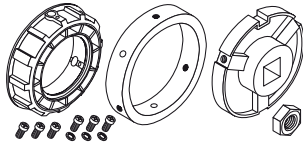

Ø149 : 9013439
Ø152 : 9013525
Ø158 : 9013526
Ø160 : 9013527
Ø168 : 9013528

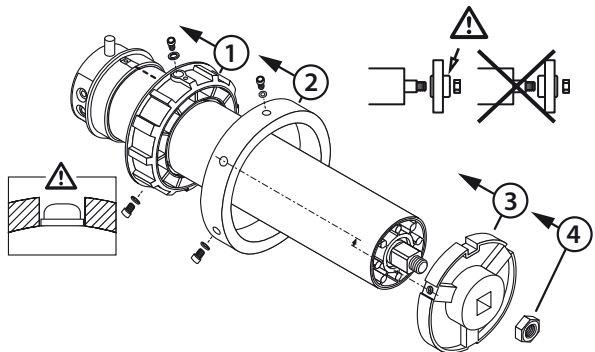

2 MONTAGE DU MOTEUR DANS LE TUBE - FITTING THE MOTOR IN THE TUBE - FIXIERUNG DES MOTORS IN DER WELLE
 MONTAGE VAN DE MOTOR IN DE WIKKELBUIS - MONTAJE DEL MOTOR EN EL EJE - MOTAGGIO NEL MOTORE DEL TUBO

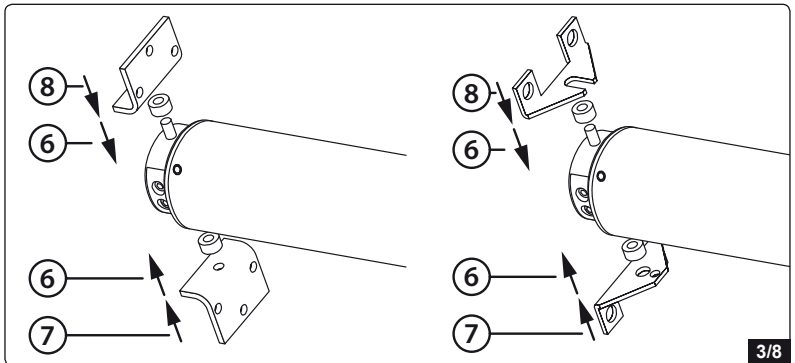
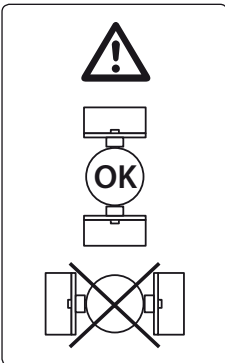
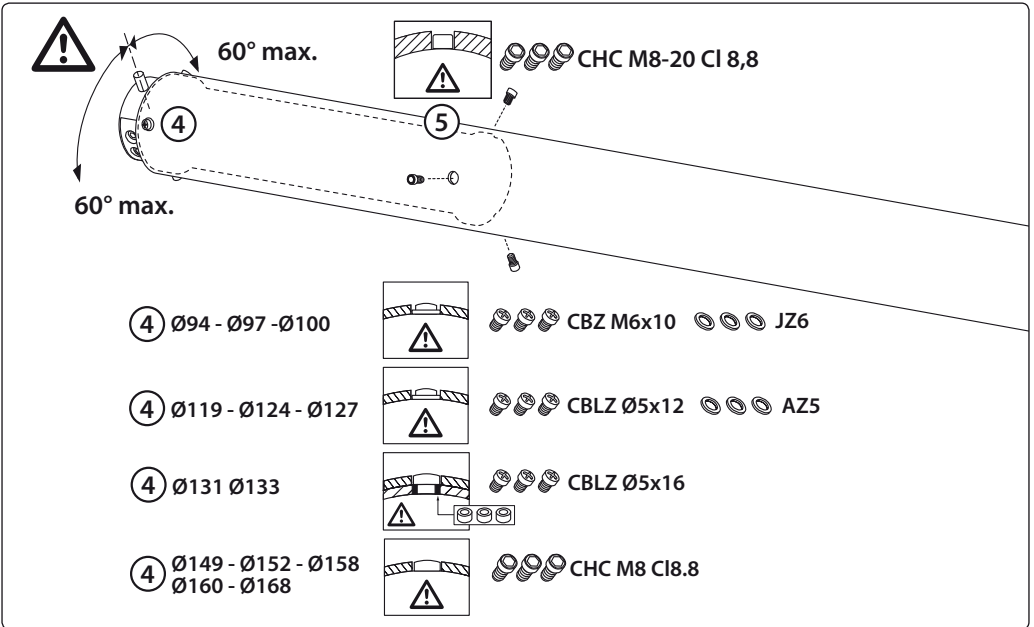
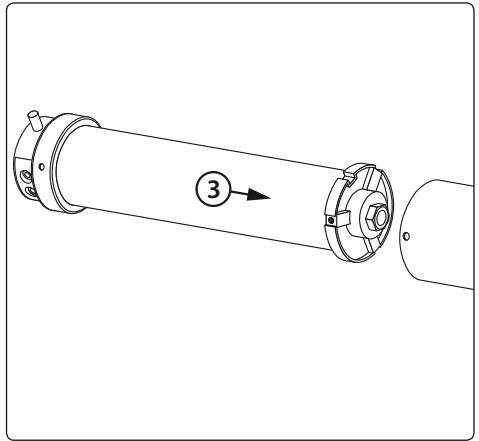
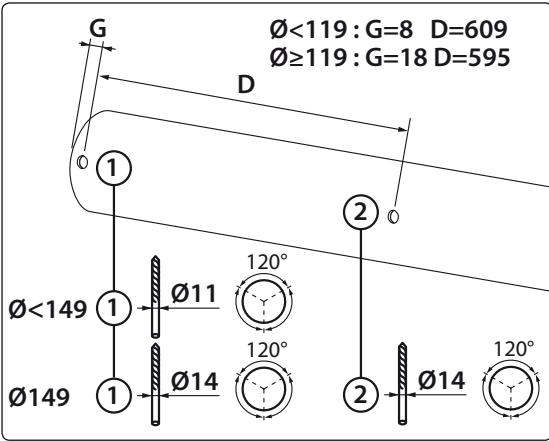

3 CABLAGE D'UN MOTEUR MONOPHASÉ - WIRING OF A SINGLE-PHASE MOTOR - BEDRADING VAN EEN 230V BUISMOTOR - ANSCHLUSS DES EINPHASEN-WECHSELSTROMMOTOR - CONEXIONADO DE UN MOTORM ONOFASICO - LIGAÇÃO DE UM MOTOR MONOFÁSICO - CABLAGGIO DI UN MOTORE MONO-FASE

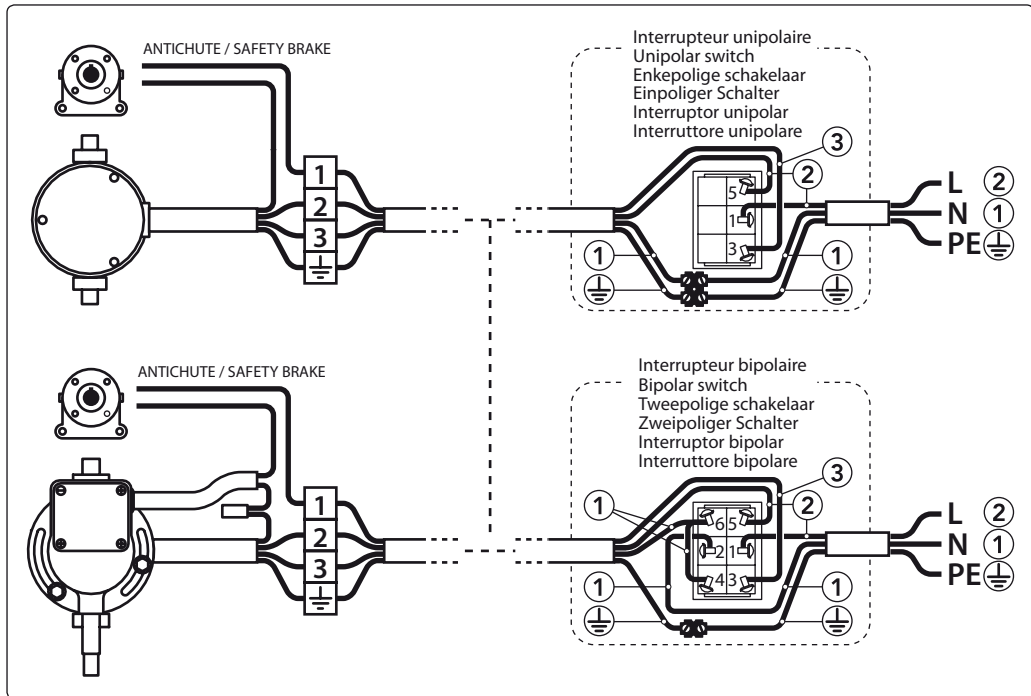

	230V-50Hz	120V-60Hz
PE	VERT / JAUNE GREEN / YELLOW GROEN / GEEL GRÜN / GELB VERDE / AMARILLO VERDE / AMARELO VERDE / GIALLO	VERT GREEN GROEN GRÜN VERDE VERDE VERDE
1	BLEU BLUE BLAUW BLAU AZUL AZUL BLU	BLANC WHITE WIT WEIß BLANCO BRANCO BIANCO
2	MARRON BROWN BRUIN BRAUN MARRÓN CASTANHO MARRONE	ROUGE RED ROD ROT ROJO VERMELHO ROSSO
3	NOIR BLACK SWART SCHWARZ NEGRO PRETO NERO	NOIR BLACK SWART SCHWARZ NEGRO PRETO NERO

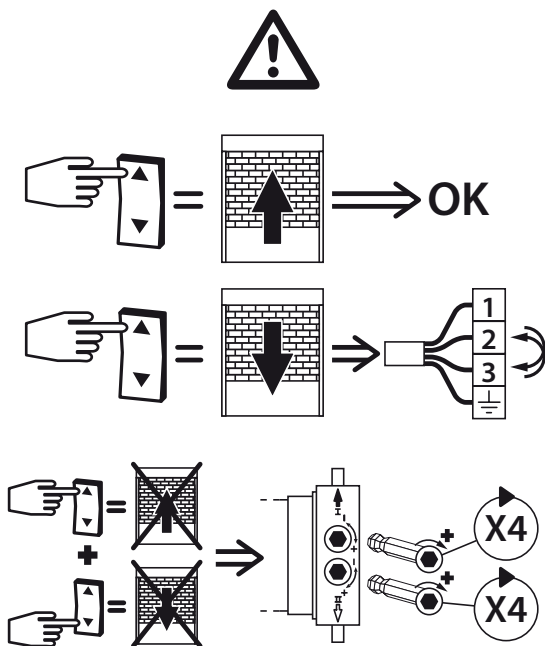

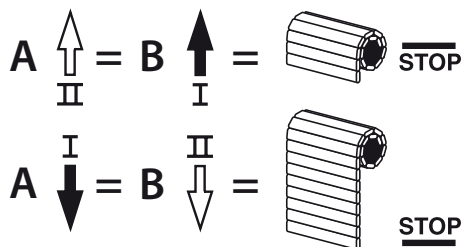
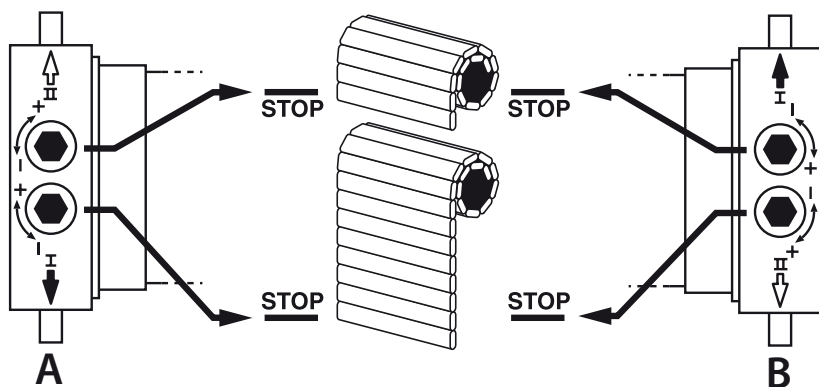
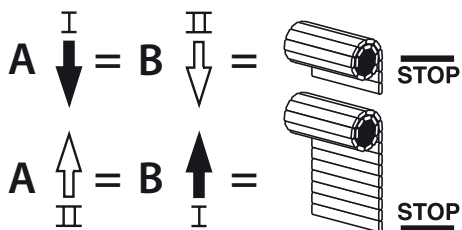
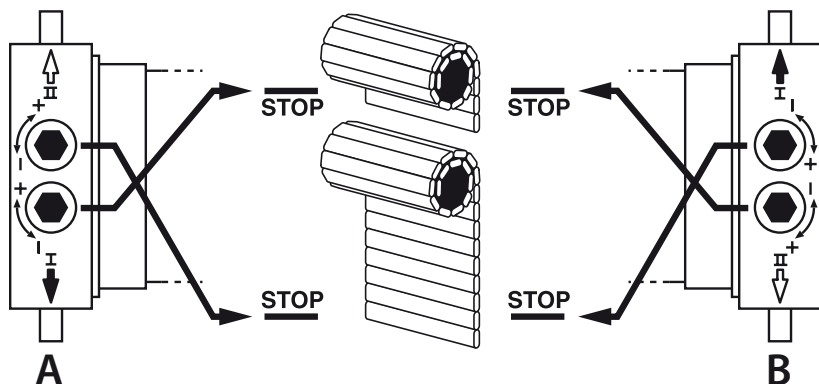

3 x 400V

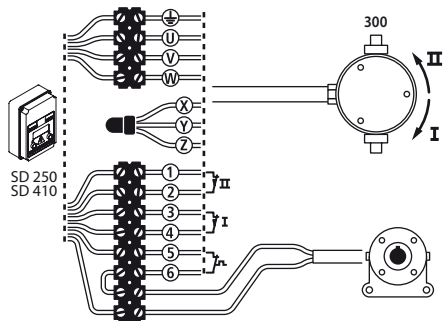
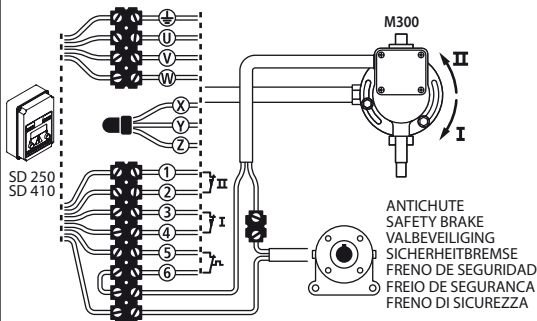

3 x 230V

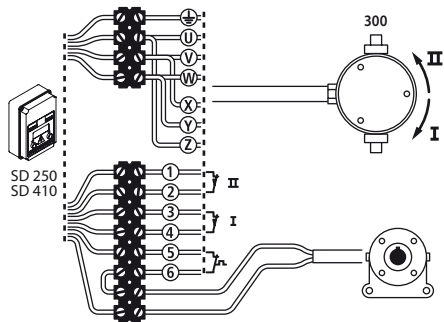
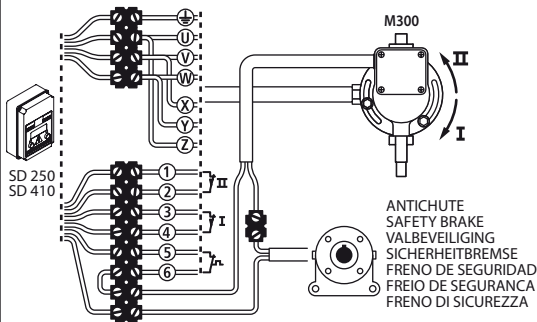

U : Bleu	FR	U : Blue	GB	U : Blau	DE	U : Blauw	NL	U : Azul	ES	U : Azul	PT	U : Blu	IT
V : Gris		V : Grey		V : Grau		V : Grijs		V : Gris		V : Pardo		V : Grigio	
W : Rouge		W : Red		W : Rot		W : Rod		W : Rojo		W : Vermelho		W : Rosso	
X : Violet		X : Purple		X : Violett		X : Paars		X : Violeta		X : Violeta		X : Violetto	
Y : Blanc		Y : White		Y : Weiß		Y : Wit		Y : Blanco		Y : Branco		Y : Bianco	
Z : Noir		Z : Black		Z : Schwarz		Z : Zwart		Z : Negro		Z : Preto		Z : Nero	
1 & 2 : Violet		1 & 2 : Purple		1 & 2 : Violett		1 & 2 : Paars		1 & 2 : Violeta		1 & 2 : Violeta		1 & 2 : Violetto	
3 & 4 : Noir		3 & 4 : Black		3 & 4 : Schwarz		3 & 4 : Zwart		3 & 4 : Negro		3 & 4 : Preto		3 & 4 : Nero	
5 : Marron		5 : Brown		5 : Braun		5 : Bruin		5 : Marrón		5 : Castanho		5 : Marrone	
6 : Gris		6 : Grey		6 : Grau		6 : Grijs		6 : Gris		6 : Pardo		6 : Grigio	
⊕ Vert / Jaune		⊕ Green / Yellow		⊕ Grün / Gelb		⊕ Groen / Geel		⊕ Verde / Amarillo		⊕ Verde / Amarelo		⊕ Verde / Giallo	

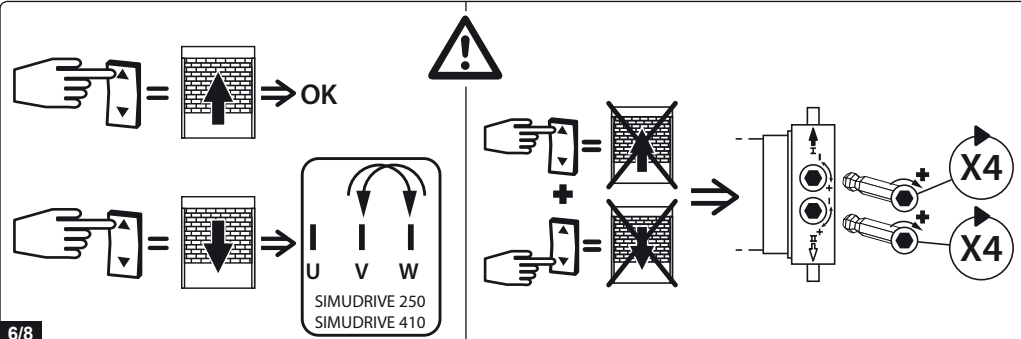

6 REGLAGE DES FIN DE COURSES - ADJUSTING THE LIMITS - EINSTELLUNG DER ENDSCHALTER
 AFSTELLING VAN DE EINDSTANDEN - AJUSTE DE FINALES DE CARRERA - REGOLAZIONE DEI FINE CORSA

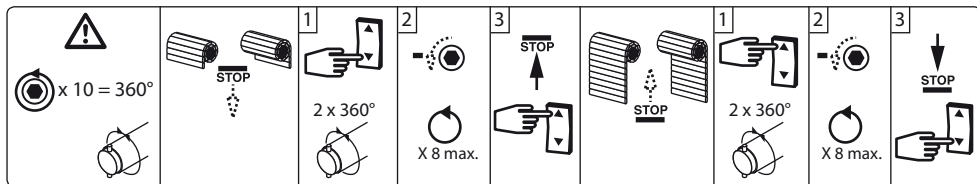
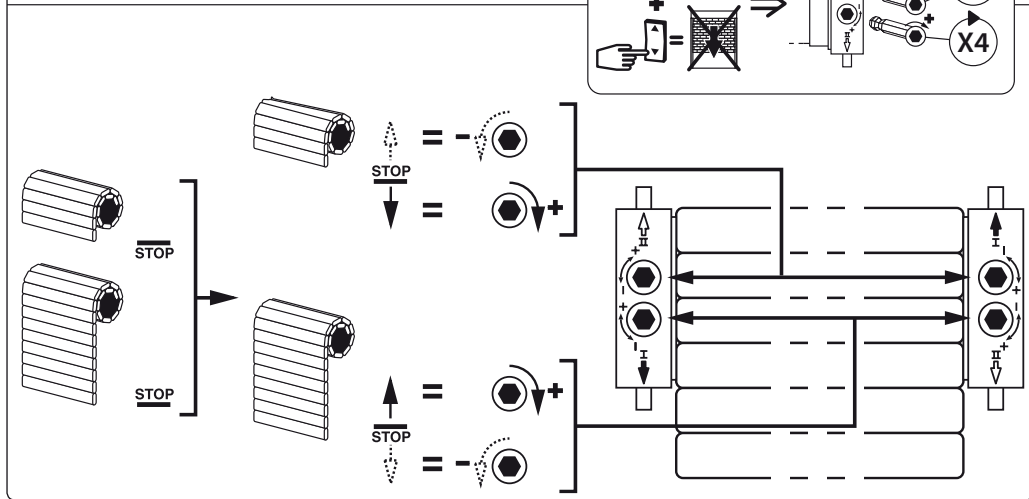
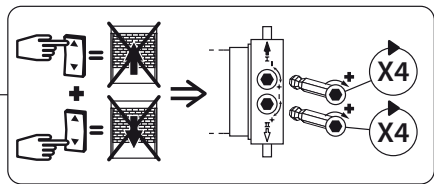
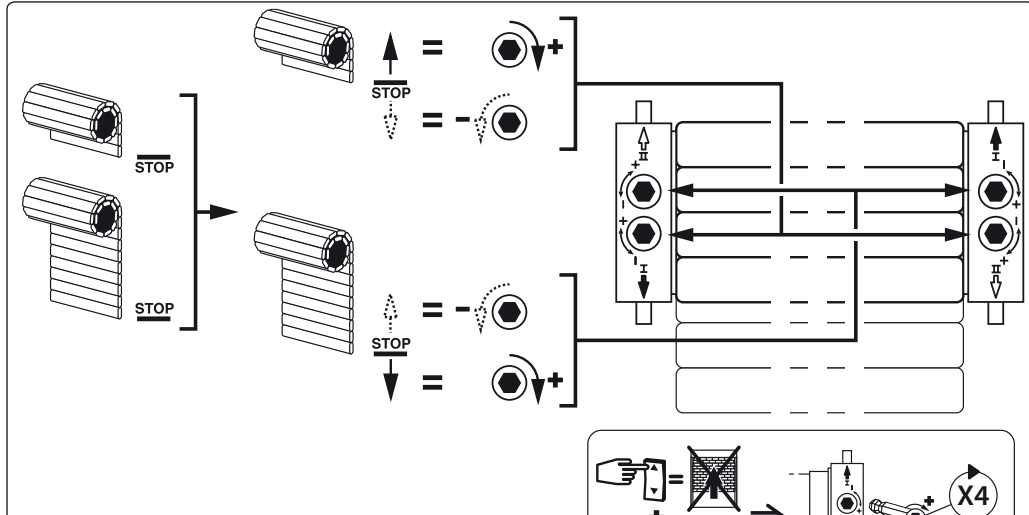
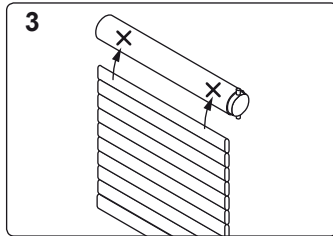
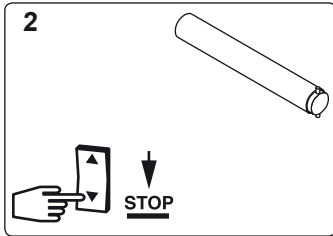
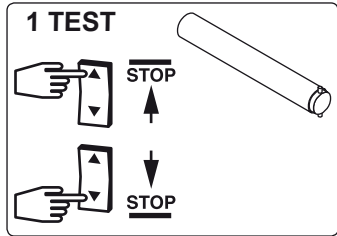

- FR-** En situation normale d'utilisation, si le moteur dépasse ces réglages initiaux et s'arrête sur son fin de course de sécurité, appelez votre personnel de maintenance pour inspection de l'installation.
- GB-** In normal use, if the motor goes over its end-limit switch adjustment and stops on its safety limit switch, call your maintenance crew to check your installation.
- NL-** Wanneer in situatie van normaal gebruik de motor deze aanvangsinstellingen overschrijdt en stopt bij beveiligingsdiefloop, moet u uw onderhoudspersoneel vragen de installatie te controleren.
- DE-** Sollte der Motor bei normalen Betriebsbedingungen diese ursprüngliche Einstellung überschreiten und an seinem Sicherheitsendschalter anhalten, wenden Sie sich sofort an Ihr Wartungspersonal für eine Nachprüfung der Anlage.
- ES-** En situación normal de uso, si el motor excede los ajustes iniciales y se detiene en su fin de recorrido deseguridad, llamar al personal de mantenimiento para que controle la instalación.
- PT-** Em situação normal de utilização, se o motor ultrapassar os ajustes iniciais e se parar no final do percurso de segurança, peça ao seu pessoal de manutenção para inspecionar a instalação.
- IT-** In una situazione normale di utilizzo, se il motore supera le regolazioni iniziali e si ferma sul fine corsa disicurezza, contattate il personale di manutenzione per controllare l'installazione



- FR-** Dans le cas d'un moteur équipé d'une manoeuvre de dépannage, le sens de la montée doit systématiquement être indiqué à l'utilisateur final. Si le moteur est combiné à un antichute :
- L'antichute doit être câblé avec le moteur.
 - Il ne faut pas utiliser la manoeuvre de dépannage lorsque l'antichute est enclenché.
- GB-** In the case of a motor with manual override system, the up direction must systematically be indicated to the end user. If the motor is combined with a safety brake:
- The safety brake must be connected to the motor.
 - The manual override system should not be used when the safety brake is engaged.
- DE-** Bei der Verwendung eines Motor mit Nothandbedienung muss die Aufwärtsrichtung für den Endverbraucher eindeutig erkennbar sein. Wenn der Motor zusammen mit einer Abrollsicherung verwendet wird :
- Die Abrollsicherung muss mit dem Motor verkabelt werden.
 - Die Nothandbedienung darf nicht benutzt werden, wenn die Abrollsicherung ausgelöst hat.
- NL-** Indien de buismotor voorzien is van een noodhandbediening, dan moet visueel aangegeven worden welke draairichting van de slinger de rolport omhoog doet bewegen. Als de buismotor gebruikt wordt in combinatie met een valbeveiling :
- De valbeveiling moet elektrisch worden aangesloten op de motor.
 - De noodhandbediening mag niet worden bedient als de valbeveiling is geactiveerd.
- ES-** En caso de un motor con accionamiento manual, la dirección de subida debeseer siempre indicada al usuario final. Si el motor está asociado a un anticaída :
- El anticaída debe estar conectado al motor.
 - El mando manual de emergencia no debe ser accionado cuando el anticaída ha actuado.
- PT-** No caso de um motor equipado de uma comando de recurso, o sentido da subida deve sistematicamente ser indicado ao utilizador final. Se o motor for combinado um freio de segurança :
- O freio de segurança deve ser cabografado com o motor.
 - Não é necessário utilizar a comando de recurso quando o freio de segurança é engrenado.
- IT-** Nel caso di un motore con manovra di soccorso, il senso dell'aumento deve sistematicamente indicato all'utilizzatore finale. Se al motore é associato un freno di sicurezza :
- Di freno di sicurezza deve essere cablato con il motore.
 - Non bisogna utilizzare la manovra di soccorso quando il freno di sicurezza é attivato.

