

animeo® IB+

Motor Controller WM 4DC/E

Installation guide

The animeo 4 DC/E Motor Controller 220-240 V AC is designed to control motors of the concept 25 motor range (24 V DC)

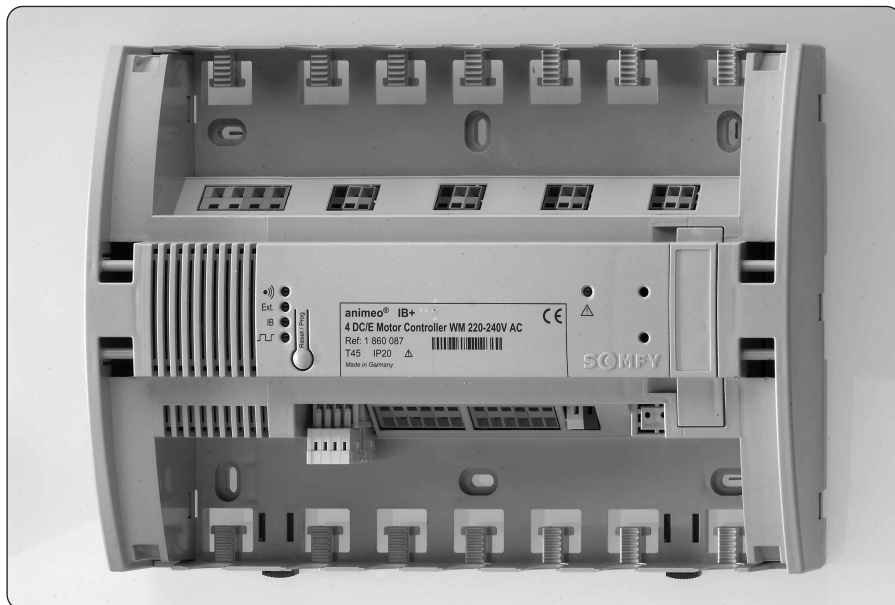

System overview

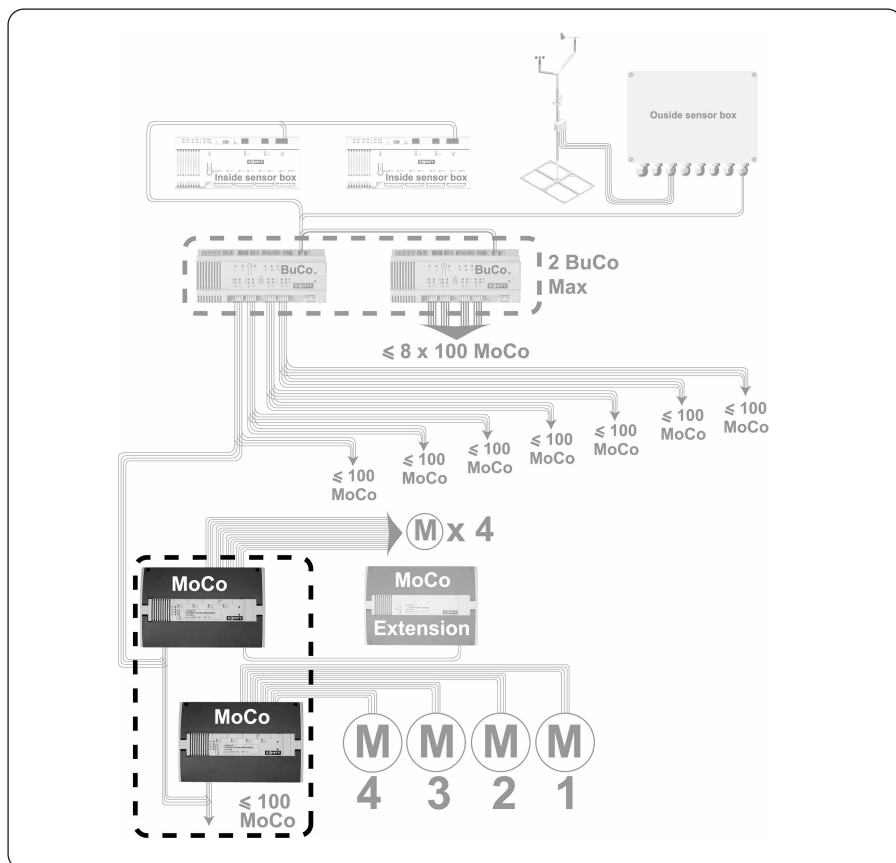

Before installation, please read and follow these instructions. An incorrect installation could lead to serious injury. The product must be installed by a qualified electrician. SOMFY's liability for defects and damages is excluded if they were caused by disregard of the instructions. Keep these instructions for future reference.

Please refer also to the manuals of the other used products.

PRODUCT REFERENCE: **1 860 087**

Table of Contents

0.	Definitions	4
1.	Mounting	5
1.1	Choose the optimal location	5
1.2	Fix the device	5
1.3	Connect power supply and wiring to other controls (cabling recommendations)	5
1.4	Fasten cables with the cable ties	6
1.5	Stick the ID number on the building plan	6
2.	Wiring	7
2.1	Recommended screwdriver	7
2.2	Wiring diagram	7
2.2.1	Push buttons possible to use	7
2.2.2	Motor outputs	8
2.3	Cable specifications	8
2.4	Check the correct running direction of the end product	8
3.	Configuration	9
3.1	Reset / Prog button	9
3.1.1	Selection of end product type	9
3.1.2	Mode selection DC or DCE	9
3.1.3	Resetting the Motor Controller to factory settings	10
3.2	Set up the Motor Controller	10
3.2.1	Running and tilting times/lengths*	10
3.2.2	Intermediate position	11
3.2.2.1	To set up intermediate position	11
3.2.2.2	To recall an intermediate position	11
3.2.2.3	To delete an intermediate position	11
3.3	Set up of configuration parameters	11
4.	Diagnostics	12
4.1	LEDs of the Motor Controller	12
4.2	Communication indications during the use	12
4.3	Small overview of the configuration	12
4.4	First level diagnostic	12
4.4.1	Attention LED (⚠)	12
4.4.2	Indication of the motor(s) concerned by the problem	13
5.	Characteristics	13

0. Definitions

The * symbols in the main text refer to the following terminology:

Running time/length	It is the dimension of the end-product. Into the software, the running time refers to the DCE and the unit is second, the running length refers to the DC and the unit is mm.
Tilting time/length	Impulses (DCE) or seconds (DC) for the slat to orientate from 90° to -90°.
Backlash	The mechanical slack can be compensated through this parameter. This is the number of pulses (DCE) or seconds (DC) before the blind starts to move the slats.
US mode	Short press (< 0.5 s): starts a full UP or DOWN operation. Long press (> 0.5 s): starts to tilt, STOP when pushbutton is released and starts a full UP or DOWN operation if the button is kept pressed.
European mode	Short press (< 0.5 s): tilt Long press (> 0.5 s): starts to tilt, STOP when pushbutton is released and starts a full UP or DOWN operation if the button is kept pressed.
Screen mode	The only possible movements are up and down.
Building Controller	The brain of the system. Connected to the PC, this device is able to store the configuration of the system. It is also able to manage the values sent by the different sensors and to send orders to the different zones. It is able to manage up to 8 zones.

1. Mounting

1.1 Choose the optimal location

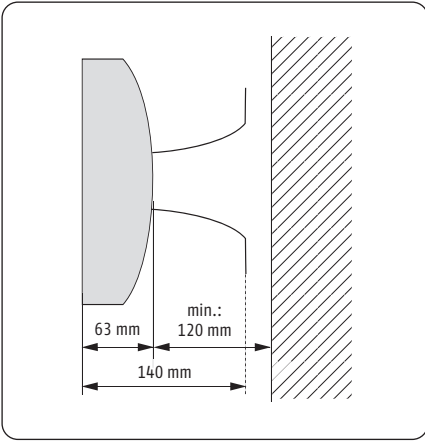

1.2 Fix the device

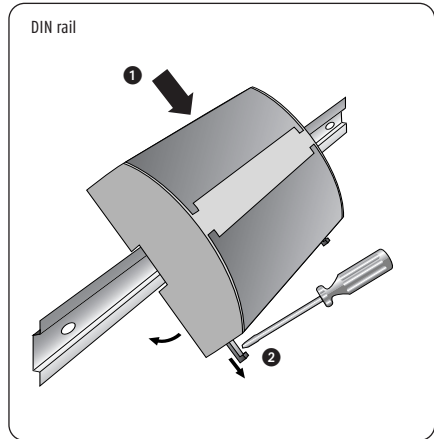
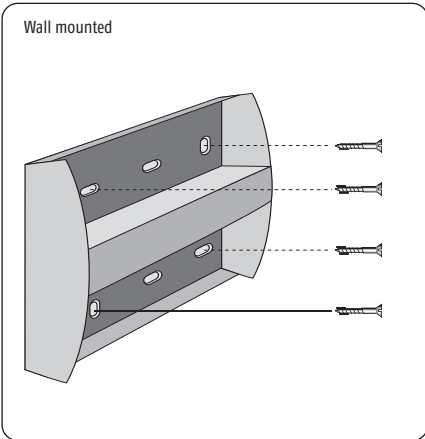

1.3 Connect power supply and wiring to other controls (cabling recommendations)

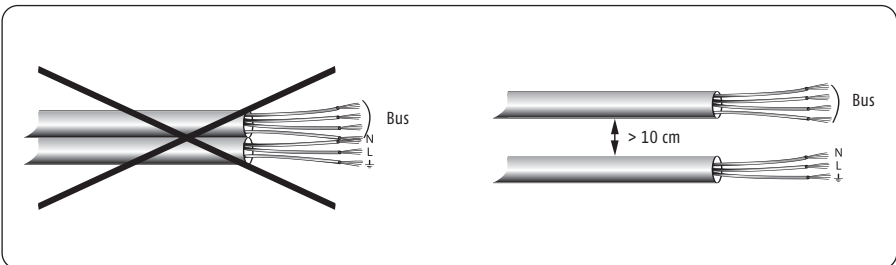

1. Mounting

1.4 Fasten cables with the cable ties

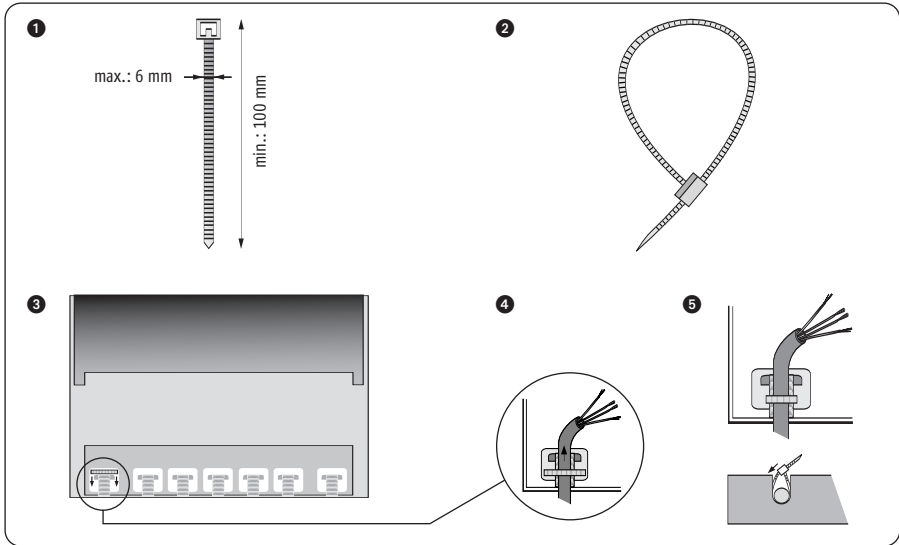

1.5 Stick the ID number on the building plan

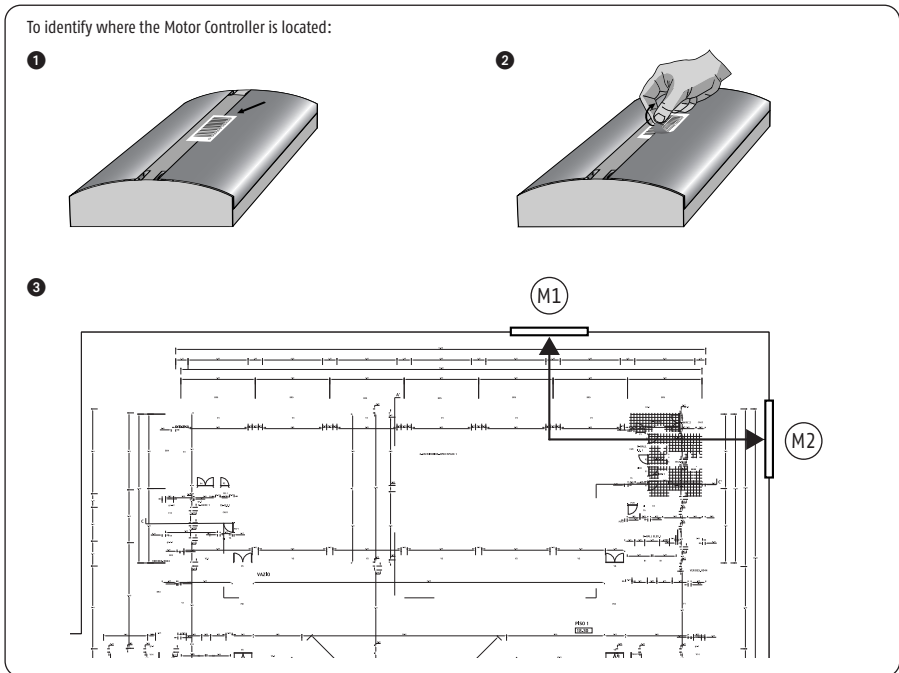

2. Wiring

2.1 Recommended screwdriver

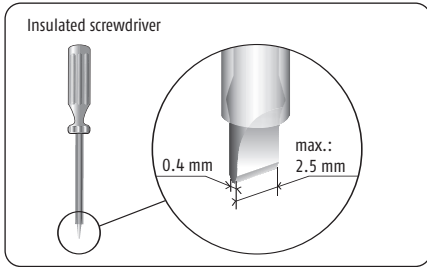

2.2 Wiring diagram

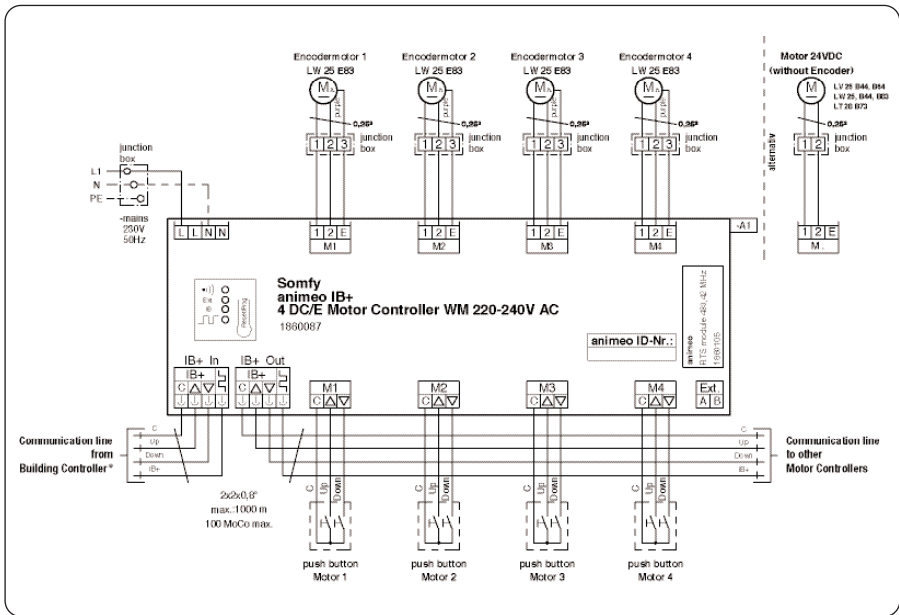

2.2.1 Push buttons possible to use

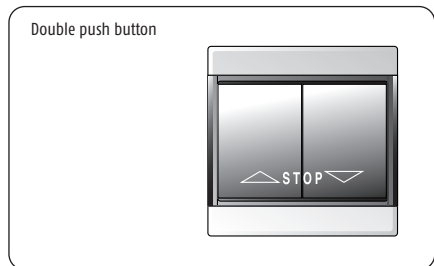

2. Wiring

2.2.2 Motor outputs

Max. current per output: 500 mA

Compatible with the following SOMFY motors in combination with CTS 25 enrolling system for venetian blinds:



LV 25-B44, -B64
DC mode
2 wires



LW 25-B44, -B83
DC mode
2 wires



LW 25-E83
DCE mode
3 wires



LT 28-B73
DC mode
2 wires

2.3 Cable specifications

Connection to	Cables	Twisted pairs	Max. distance
Motors	Min.: 2 x 0.6 mm ² /19 AWG Max.: 2 x 2.5 mm ² /13 AWG	-	20 m
Motor Controller Extension	Min.: 2 x 0.6 mm ² /19 AWG Max.: 2 x 2.5 mm ² /13 AWG	Required	50 m
Switches	Min.: 3 x 0.6 mm ² /19 AWG Max.: 3 x 2.5 mm ² /13 AWG	Recommended	100 m
IB+ input/output	Min.: 4 x 0.6 mm ² /19 AWG Max.: 4 x 1.5 mm ² /16 AWG	Recommended	1000 m
Power supply	Min.: 3 x 0.75 mm ² /16 AWG Max.: 3 x 2.5 mm ² /13 AWG	-	-

2.4 Check the correct running direction of the end product

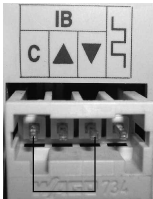

DOWN (C + ▼)
The end product should go down



UP (C + ▲)
The end product should go up

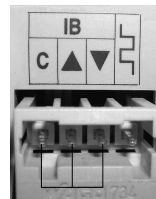

STOP (C + ▼ + ▲)
The end product should stop

3. Configuration

3.1 Reset / Prog button

With this button, you can access the basic configuration of the Motor Controller.

3.1.1 Selection of end product type

Local push button ergonomics and the type of end products to be preselected:

- Venetian blind, European mode *
- Venetian blind, US mode *
- Screen mode *

The default mode of function is venetian blind, US mode *.

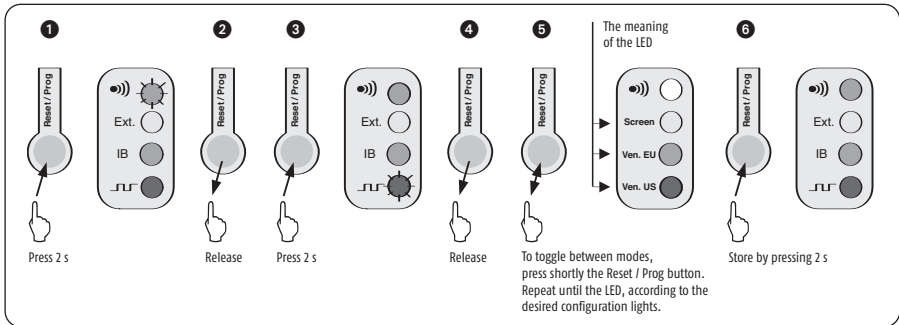

3.1.2 Mode selection DC or DCE

The type of motors controlled:

- DC
- DCE (in case of the use of a LW25-E83 motor, recognizable by the 3 wires)

The default mode of function is DCE.

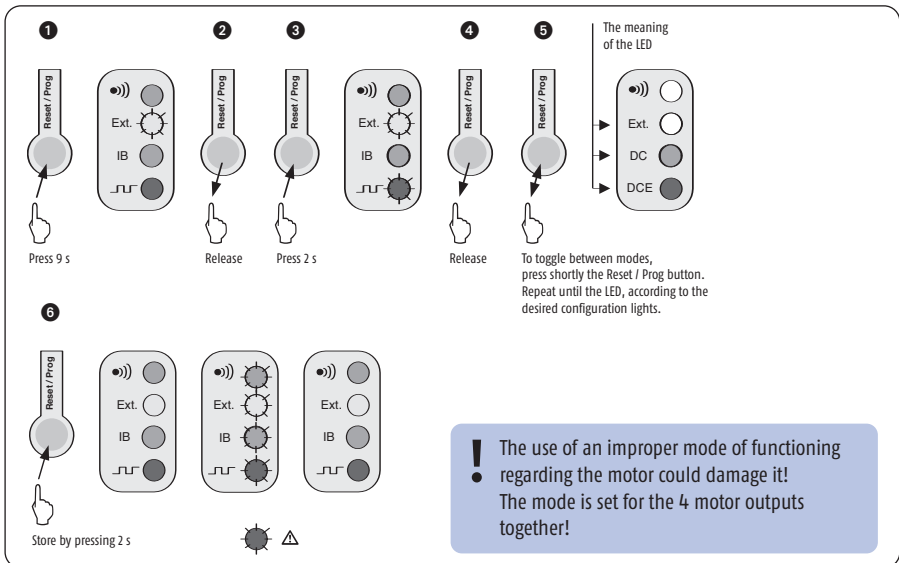

3. Configuration

3.1.3 Resetting the Motor Controller to factory settings

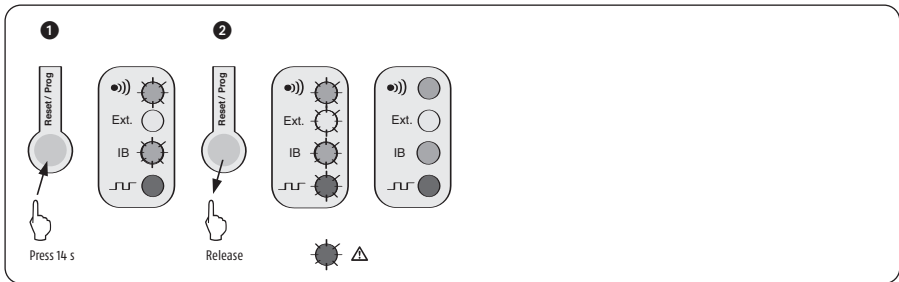

3.2 Set up of the Motor Controller

This section describes the set up of the running time/length *, the tilting time/length * and an intermediate position of the Motor Controller through the remote control or the wired switch.

3.2.1 Running and tilting times/lengths *

For installers knowing the Motor Controller 4DC, the procedure on the 4DC/DCE is the same. When you use the Motor Controller for the first time (or after a reset), a default running time/length* of around 35 cm (DCE) or 3 Minutes (DC) is already set up. The default tilt pulses are 110 (for DCE, should fit for 25 mm slats in combination with CTS 25 enrolling system) or 3 s (DC).

To set the tilting times/lengths * only, you have to do the procedure from the beginning and also reprogram the running times/lengths *. After learning running and tilting times/lengths *, a complete UP order has to be given so that the blind can identify its upper reference point.

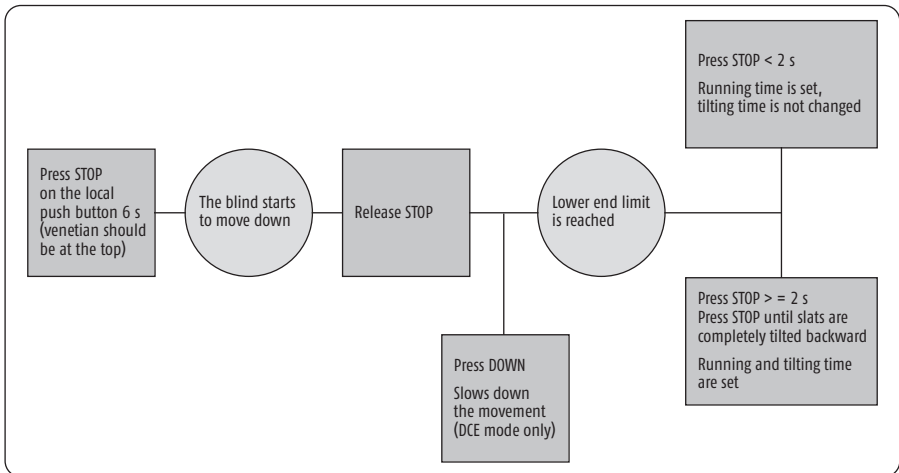

3. Configuration

3.2.2 Intermediate position

A position that is set by the user with the local control. This can be any position between the upper and the lower end limit. The intermediate position could only be set after running & tilting times/lengths* are set!

3.2.2.1 To set up an intermediate position

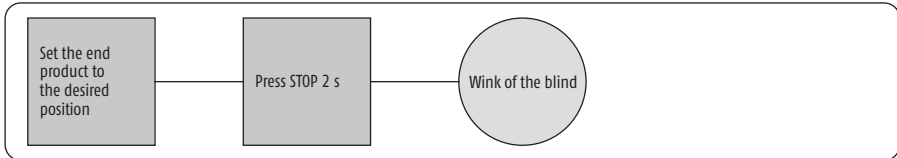

3.2.2.2 To recall an intermediate position

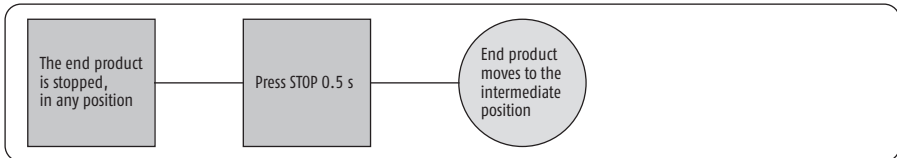

3.2.2.3 To delete an intermediate position

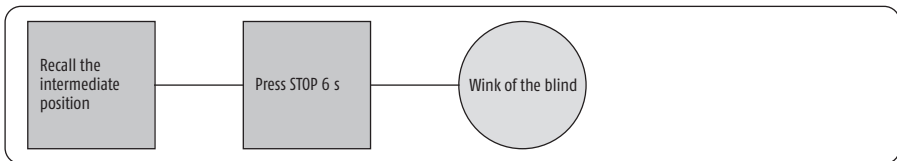

3.3 Set up of configuration parameters

All the configuration parameters can be set via PC and Building Controller by using the Operating Software or the Operating Interface (see “animeo Compact Operating Interface” or “Operating Software” installation guide).

Only the animeo System/Operating Software > = version 2.1 is compatible
 Only the Building Controller* > = Index B is compatible

Via the animeo Operating Software or the Compact Software, following parameters can be set:

Parameters	Operating Software	Compact Software
Running and tilting times/lengths*	•	•
Backlash*	•	•
Speeds for the UP/DOWN/TILT movements	•	•
Intermediate position*	•	-
Default position: The position when the end-product is not in use (e.g. after a reset)	•	-

4. Diagnostics

4.1 LEDs of the Motor Controller

The LEDs on the front side of the Motor Controller can be used to have:

- Communication indications during the use (remote signal, IB+, ...)
- A reduced overview of the configuration
- A first level diagnostic

4.2 Communication indications during the use

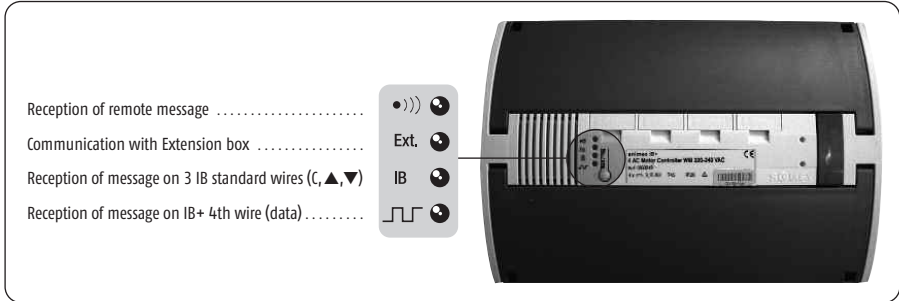

4.3 Small overview of the configuration

Press shortly the Reset / Prog button (< 0.5 s)

LED	On (2 s)	Blinking
Green	Remote control detected	No remote control
Yellow	Screen with R&T times recorded	Screens without R&T times recorded
Orange	Venetian blinds European ergonomics with R&T times recorded	Venetian blinds European ergonomics without R&T times recorded
Red	Venetian blinds USA ergonomics with R&T times recorded	Venetian blinds USA ergonomics without R&T times recorded
▲ = Red	DCE	-
▲ = Yellow	DC	-

R&T times: Running and tilting times

4.4 First level diagnostic

4.4.1 Attention LED (▲)

If ▲ or ▼ pressed and the Attention LED (▲) blinks in red (overcurrent), the following points should be checked:

- Short circuit on motor output or at least one cable is disconnected
- Encoder wire connected to a motor output connector marked with +/-
- Motor Controller in DC mode but DCE motors connected

If ▲ or ▼ pressed and the Attention LED (▲) blinks in yellow (regulation error): The set speed is too high regarding the size of the blind. Enter a lower speed in the Operating Software.

4. Diagnostics

4.4.2 Indication of the motor(s) concerned by the problem

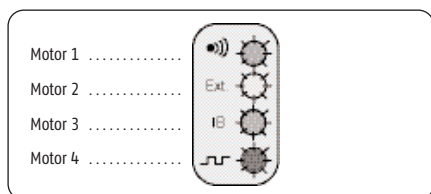

To disable the error indicator, press shortly (< 0.5 s) the Reset / Prog button.

5. Characteristics

Motor Controller WM 4DC/E 220-240 V AC		Ref.: 1 860 087
Supply	Voltage	220-240 V AC
	Max. operating current	4 x 500 mA
	Standby power consumption	3.5 VA
	Max. operating current (primary) in standby	16 mA
	Fuses	T4A (not removable)
Mechanical data	Housing	Wall mounted
	Length / Height / Width	155 / 63 / 180 mm
	Weight	780 g
	Plastic	Type: PC ABS polycarbonate
Housing material	Recyclable	
Protection code	IP20	
Operating elements	Configuration mode & reset push button	
Inputs/Outputs	Short circuit secured	
Output power/motor output	Max. 500 mA at 24 V DC	
Temperature ranges	Operating temp.	0 °C to 45 °C
	Storage temp.	-20 °C to 70 °C
	Relative humidity	85 %
Conformity	CE by EN 60730-1:2000	
Wire length Motor Controller to motor	Max. 20 m	

AUSTRIA
SOMFY GesmbH
www.somfy.at
Tel.: (43) 662 62 53 08

AUSTRALIA
SOMFY Pty Limited
www.somfy.com.au
Tel.: (61) 2 9638 0744

BELGIUM
SOMFY NV SA
www.somfy.be
Tel.: (32) 2 712 07 70

BRASIL
SOMFY BRASIL Ltda
www.somfy.com.br
Tel.: (55-11) 6161 6613

CANADA
SOMFY ULC
www.somfy.com
Tel.: (1) 905 564 6445

PR CHINA
SOMFY China Co Ltd.
www.somfy.com.ch
Tel.: (86-21) 6280 9660

CHINA
SOMFY Shanghai
www.somfy.com.ch
Tel.: (86) 21 6280 9660

CYPRUS
SOMFY Middle East Co. Ltd.
www.somfy.com
Tel.: (357) 25 34 55 40

CZECH REPUBLIC
SOMFY Spol s.r.o
www.somfy.cz
Tel.: (420) 296 37 24 86-7

FINLAND
SOMFY Finland AB
www.somfy.com
Tel.: (358) 9 57 130 230

FRANCE
SOMFY France
www.somfy.fr
Tel.: (33) 4 50 96 70 96

GERMANY
SOMFY GmbH
www.somfy.de
Tel.: (49) 74 72 93 00

GREECE
SOMFY Hellas SA
www.somfy.com
Tel.: (30) 210 614 67 68

HONG KONG
SOMFY Co. Ltd.
www.somfy.com
Tel.: (852) 2523 63 39

HUNGARY
SOMFY Kft
www.somfy.hu
Tel.: (36) 1814 5120

INDIA
SOMFY India Private Limited
www.somfy.co.in
Tel.: (91) 11 51659176

ISRAEL
SISA HOME AUTOMATION LTD
www.somfy.com
Tel.: (972) 952 55 54

ITALY
SOMFY Italia S.R.L
www.somfy.it
Tel.: (39) 02 48 47 181

JAPAN
SOMFY K.K
www.somfy.co.jp
Tel.: (81) 45 475 07 32

KOREA
SOMFY JOO
www.somfy.com.kr
Tel.: (82) 2 594 4331

KUWAIT
SOMFY Kuwait
www.somfy.com
Tel.: (965) 53 39 592

LEBANON
SOMFY Lebanon
www.somfy.com
Tel.: (961) 1 391 224

MEXICO
SOMFY MEXICO SA de CD
www.somfy.com.mx
Tel.: (11) 525 576 3421

NETHERLANDS
SOMFY Nederland B.V
www.somfy.nl
Tel.: (31) 23 55 44 900

POLAND
SOMFY SP Z.O.O
www.somfy.pl
Tel.: (48) 22 818 02 97
(48) 22 618 80 56

PORTUGAL
SOMFY Portugal
www.somfy.com
Tel.: (351) 229 396 840

RUSSIA
SOMFY LLC
www.somfy.com
Tel.: (7) 095 3 60 41 86

SINGAPORE
SOMFY PTE LTD
www.somfy.com.sg
Tel.: (65) 638 33 855

SPAIN
SOMFY Espana SA
www.somfy.com
Tel.: (34) 93 480 09 00

SWEDEN
SOMFY Nordic AB
www.somfynordic.com
Tel.: (46) 40 165 900

SWITZERLAND
SOMFY AG
www.somfy.ch
Tel.: (41) 18 38 40 30

UNITED KINGDOM
SOMFY Ltd.
www.somfy.co.uk
Tel.: (44) 113 391 3030

USA
SOMFY Systems Inc.
www.somfysystems.com
Tel.: (1) 609 395 1300